



US 20140306195A1

(19) **United States**
(12) **Patent Application Publication**
Oh et al.

(10) **Pub. No.: US 2014/0306195 A1**
(43) **Pub. Date: Oct. 16, 2014**

(54) **ORGANIC LIGHT-EMITTING DISPLAY APPARATUS AND MANUFACTURING METHOD THEREOF**

Publication Classification

(71) Applicant: **Samsung Display Co., Ltd.,**
Yongin-City (KR)

(51) **Int. Cl.**
H01L 27/32 (2006.01)
H01L 51/56 (2006.01)

(72) Inventors: **Min-Ho Oh**, Yongin-City (KR);
Yoon-Hyeung Cho, Yongin-City (KR);
Yong-Tak Kim, Yongin-City (KR);
So-Young Lee, Yongin-City (KR);
Jong-Woo Kim, Yongin-City (KR);
Ji-Young Moon, Yongin-City (KR)

(52) **U.S. Cl.**
CPC **H01L 27/3295** (2013.01); **H01L 51/56** (2013.01)
USPC **257/40; 438/28**

(57) **ABSTRACT**

An organic light-emitting display apparatus and a manufacturing method thereof. The organic light-emitting display apparatus includes a substrate, a display unit arranged on the substrate, a dam unit arranged at a periphery of the display unit and on the substrate and an encapsulating layer to encapsulate the display unit, wherein the encapsulating layer includes an organic film covering the display unit, and an inorganic film covering the organic film and the dam unit, and wherein a hardness of the dam unit is lower than that of the inorganic film. According to this, lateral moisture-proof characteristics of the organic light-emitting display apparatus are improved.

(21) Appl. No.: **14/036,430**

(22) Filed: **Sep. 25, 2013**

(30) **Foreign Application Priority Data**

Apr. 12, 2013 (KR) 10-2013-0040547

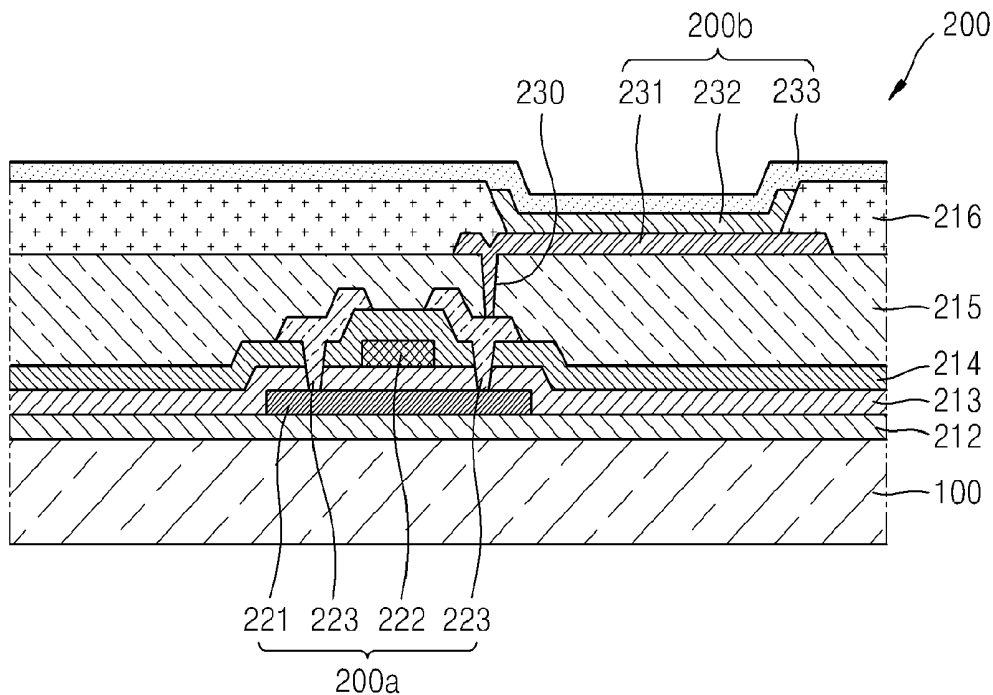

FIG. 1

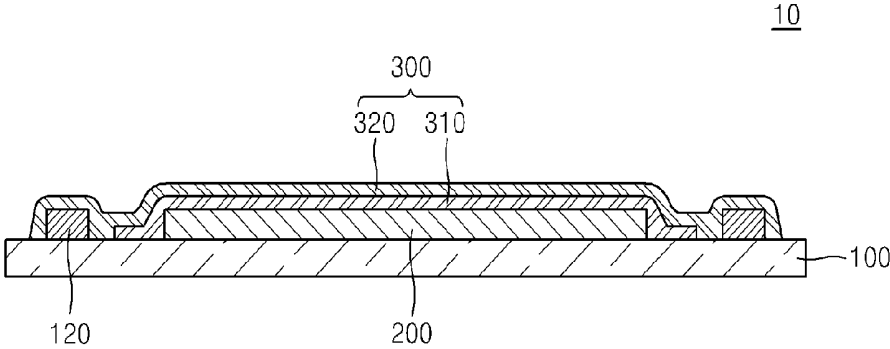

FIG. 2

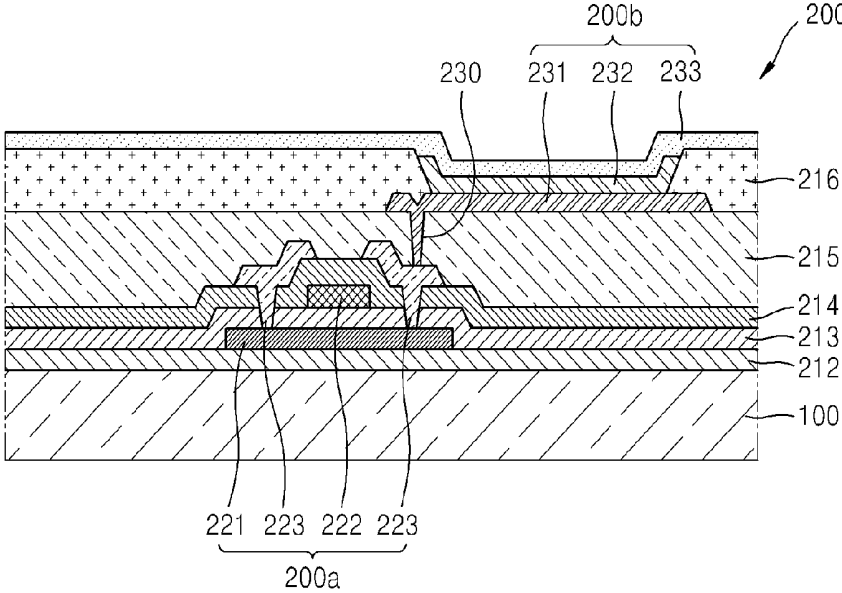

FIG. 3

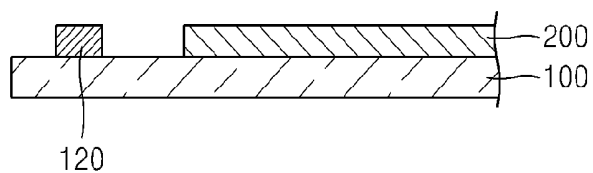

FIG. 4

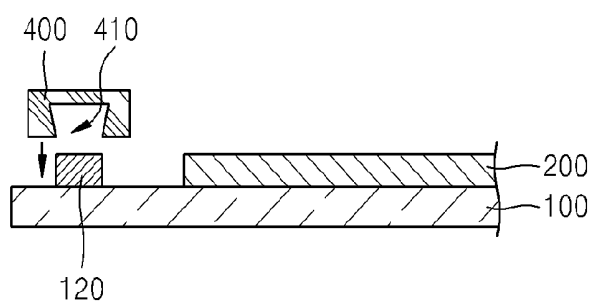

FIG. 5

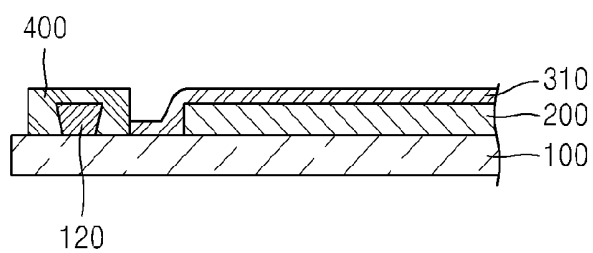
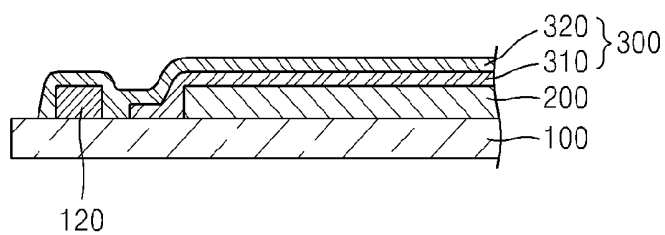

FIG. 6



**ORGANIC LIGHT-EMITTING DISPLAY
APPARATUS AND MANUFACTURING
METHOD THEREOF**

CLAIM OF PRIORITY

[0001] This application makes reference to, incorporates the same herein, and claims all benefits accruing under 35 U.S.C. §119 from an application earlier filed in the Korean Intellectual Property Office filed on Apr. 12, 2013 and there duly assigned Serial No. 10-2013-0040547.

BACKGROUND OF THE INVENTION

[0002] 1. Field of the Invention

[0003] The present invention relates to an organic light-emitting display apparatus and a manufacturing method thereof in which lateral moisture-proof characteristics are improved.

[0004] 2. Description of the Related Art

[0005] An organic light-emitting display apparatus includes an organic light-emitting device including a hole injection electrode, an electron injection electrode, and an organic light-emitting layer interposed between them. The organic light-emitting display apparatus is a self-emissive display apparatus where holes injected from the hole injection electrode and electrons injected from the electron electrode are combined to create excitons in the organic light-emitting layer, and the excitons decay from an excited state to a ground state to emit a light beam.

[0006] Since the organic light-emitting display apparatus, which is a self-emissive display apparatus, does not need separate light sources, low voltage driving and a lightweight and thin type configuration may be possible. The organic light-emitting display apparatus attracts the attention as a next generation display apparatus due to high definition characteristics, such as wide viewing angles, high contrast, and fast response speeds. However, since the organic light-emitting display apparatus is degraded by external moisture or oxygen, it is required to be encapsulated to protect the organic light-emitting device from external moisture or oxygen.

[0007] Nowadays, for a thinner and more flexible organic light-emitting display apparatus, a thin film encapsulation (TFE) layer, including organic films and inorganic films, is used to encapsulate the organic light-emitting device.

[0008] When the organic films and the inorganic films are formed, patterns are formed by disposing masks corresponding to the films on a substrate. At this time, an organic film may permeate a gap between the mask used to produce the organic film pattern and the substrate. Compared to an inorganic film, the organic film has remarkably lower encapsulation characteristics. Therefore, when an organic film permeates a gap between the substrate and the mask used to pattern the organic film, an organic film may be formed between the inorganic film and the substrate, or between the inorganic films. Also, through this, oxygen or moisture may permeate the display unit.

SUMMARY OF THE INVENTION

[0009] The present invention provides an organic light-emitting display apparatus and a manufacturing method thereof in which lateral moisture-proof characteristics thereof are improved.

[0010] According to one aspect of the present invention, there is provided an organic light-emitting display apparatus

that includes a substrate, a display unit arranged on the substrate, a dam unit arranged at a periphery of the display unit and on the substrate and an encapsulating layer to encapsulate the display unit, wherein the encapsulating layer includes an organic film covering the display unit, and an inorganic film covering the organic film and the dam unit, and wherein the hardness of the dam unit may be lower than that of the inorganic film. The organic film may be spaced apart from the dam unit. The dam unit may include silicon, an epoxy or an acryl. The dam unit may include a plurality of dams spaced apart from each other and parallel to each other. The dam unit may have elasticity. The organic film may include polyurea or polyacrylate. The inorganic film may include SiN_x , Al_2O_3 , SiO_2 or TiO_2 . The display apparatus may also include a lower inorganic film covering the display unit and the dam unit, the organic film may cover the lower inorganic film. The plurality of dams may be concentric rectangles that increase a length of a lateral path of moisture in reaching the display unit from an outside.

[0011] According to one aspect of the present invention, there is provided a method of manufacturing an organic light-emitting display apparatus that includes forming a dam unit on a substrate, forming a display unit inside the dam unit and on the substrate and forming an encapsulating layer on the display unit to encapsulate the display unit, the forming of the encapsulating layer may include combining a mask with the substrate, the mask having a groove into which the dam unit is inserted, forming an organic film to cover the display unit by using the mask, separating the mask and forming an inorganic film to cover the organic film and the dam unit. A depth of the groove may be equal to or smaller than a height of the dam unit, and a width of the groove may be equal to or greater than a width of the dam unit. The dam unit may include silicon, an epoxy or an acryl. The dam unit may be produced by inkjet printing or screen printing. The groove may have a tapered shape. When the dam unit is combined to the groove, a shape of the dam unit may change elastically according to a shape of the groove. The organic film may be spaced apart from the dam unit. A hardness of the dam unit may be lower than that of the inorganic film. The method may also include forming a lower inorganic film to cover the display unit and the dam unit, wherein the organic film may be formed to cover a portion of the lower inorganic film, and wherein the combining the mask to the substrate may include inserting the dam unit covered by the lower inorganic film into the groove of the mask.

BRIEF DESCRIPTION OF THE DRAWINGS

[0012] A more complete appreciation of the invention, and many of the attendant advantages thereof, will be readily apparent as the same becomes better understood by reference to the following detailed description when considered in conjunction with the accompanying drawings, in which like reference symbols indicate the same or similar components, wherein:

[0013] FIG. 1 is a side view schematically illustrating an organic light-emitting display apparatus according to an embodiment of the present invention;

[0014] FIG. 2 is an enlarged cross-sectional view illustrating a display unit of the organic light-emitting display apparatus in FIG. 1;

[0015] FIG. 3 illustrates a cross-sectional view schematically illustrating a method of manufacturing the organic light-emitting display apparatus where the display unit is formed after the dam unit;

[0016] FIG. 4 illustrates a cross-sectional view schematically illustrating a method of manufacturing the organic light-emitting display apparatus where the mask is attached to the dam unit of the display unit;

[0017] FIG. 5 illustrates a cross-sectional view schematically illustrating a method of manufacturing the organic light-emitting display apparatus where an organic unit is formed on the display; and

[0018] FIG. 6 illustrates a cross-sectional view schematically illustrating a method of manufacturing the organic light-emitting display apparatus where the inorganic layer is formed.

DETAILED DESCRIPTION OF THE INVENTION

[0019] The following description with reference to the accompanying drawings is provided to assist in a comprehensive understanding of exemplary embodiments of the invention as defined by the claims and their equivalents. It includes various specific details to assist in that understanding, but these are to be regarded as merely exemplary. Accordingly, those of ordinary skill in the art will recognize that various changes and modifications of the embodiments described herein can be made without departing from the scope and spirit of the invention. Also, any description that may unnecessarily blur the point of the present invention is omitted from the

DETAILED DESCRIPTION

[0020] Also, though terms like “first” and “second” are used to describe various elements and/or portions in various embodiments of the present invention, the members and/or portions are not limited to these terms. These terms are used only to differentiate one member or portion from another one.

[0021] It will also be understood that when a portion such as a layer, a film, a region, a plate is referred to as being “on” or “above” another portion, it can be directly on the other portion, or intervening layers may also be present.

[0022] Hereinafter, exemplary embodiments of the inventive concept will be described in detail with reference to the accompanying drawings. In the specification, descriptions or drawings on portions irrelevant to the present invention will be omitted, or briefly described or drawn. Like reference numerals refer to like elements throughout. Also, in the drawings, the thicknesses and areas of layers and regions are enlarged or exaggerated for clarity.

[0023] As used herein, the term “and/or” includes any and all combinations of one or more of the associated listed items. Expressions such as “at least one of,” when preceding a list of elements, modify the entire list of elements and do not modify the individual elements of the list.

[0024] Turning now to FIGS. 1 and 2, FIG. 1 is a side view schematically illustrating an organic light-emitting display apparatus 10 according to an embodiment of the present invention, and FIG. 2 is an enlarged cross-sectional view illustrating a display unit 200 of the organic light-emitting display apparatus 10 of FIG. 1. Referring to FIGS. 1 and 2, the organic light-emitting display apparatus 10 includes a substrate 100, the display unit 200 formed on the substrate 100, a

dam unit 120 spaced-apart from the display unit 200 and on the substrate 100, and an encapsulating layer 300 encapsulating the display unit 200.

[0025] The substrate 100 may be a flexible substrate and may be made out of plastic having excellent thermal resistance and durability, such as polyimide, polyethylene terephthalate (PET), polycarbonate, polyethylene naphthalate, polyarylate (PAR), and polyetherimide, however the present invention is not limited thereto, as the substrate 100 may instead be made out of various other materials, such as metal or glass.

[0026] The display unit 200 may include an organic thin film transistor (TFT) layer 200a and a pixel unit 200b. The pixel unit 200b may be an organic light-emitting device. Hereinafter, the display unit 200 will be described in detail with reference to FIG. 2.

[0027] A buffer layer 212 may be formed on the substrate 100. The buffer layer 212 prevents impurities from permeating through the substrate 100, and provides a flat surface on a top side of the substrate 100. The buffer layer 212 may be made out of various materials capable of performing the above-described functions.

[0028] For example, the buffer layer 212 may include an inorganic material, such as silicon oxide, silicon nitride, silicon oxy-nitride, aluminum oxide, aluminum nitride, titanium oxide, or titanium nitride, or an organic material, such as polyimide, polyester, or acrylic. Alternatively, the buffer layer can be a plurality of laminated layers of organic layers and inorganic layers alternately stacked.

[0029] A TFT layer 200a may be formed on the buffer layer 212. The TFT layer 200a may include an activation layer 221, a gate electrode 222, and source and drain electrodes 223. Although, as an example of the TFT layer 200a in the present embodiment, a top gate-type TFT is illustrated, a TFT having another structure may also be included.

[0030] The activation layer 221 is made out of a semiconductor material and is arranged on the buffer layer 212, and a gate insulating film 213 is formed to cover the activation layer 221. The activation layer 221 may be made out of an inorganic semiconductor, such as amorphous silicon or poly-silicon, or an organic semiconductor, and have a channel region between a source region and a drain region. Also, the gate insulating film 213 insulates the activation layer 221 from the gate electrode 222, and may be made out of an organic material or an inorganic material, such as SiNx or SiO₂.

[0031] The gate electrode 222 is formed on the gate insulating film 213, and an inter-layer insulating film 214 is formed to cover the gate electrode 222. The gate electrode 222 may include Au, Ag, Cu, Ni, Pt, Pd, Al, or Mo, and an alloy, such as Al:Nd, or Mo:W alloy, but it is not limited thereto as the gate electrode 222 may be made out of various other materials in consideration of design conditions. The inter-layer-insulating film 214 is disposed between the gate electrode 222 and the source and drain electrodes 223 to insulate them from each other, and may be made out of an inorganic material, such as SiNx or SiO₂.

[0032] The source and drain electrodes 223 are formed on the inter-layer insulating film 214. In detail, the inter-layer insulating film 214 and the gate insulating layer 221 expose the source and drain regions of the activation layer 221, and the source and drain electrodes 223 contact the exposed source and drain regions of the activation layer 221.

[0033] FIG. 2 exemplifies a top gate-type TFT, which sequentially includes the activation layer 221, the gate elec-

trode **222**, and the source and drain electrodes **223**, however the present invention is not limited thereto, and the gate electrode **222** may be disposed below the activation layer **221**. The above-described TFT layer **200a** is electrically connected to the pixel unit **200b** to drive the pixel unit **200b**, and is protected by being covered by the planarization layer **215**.

[0034] The planarization layer **215** may include an inorganic insulating film and/or an organic insulating film. For the inorganic insulating film, SiO_2 , SiN_x , SiON , Al_2O_3 , TiO_2 , Ta_2O_5 , HfO_2 , ZrO_2 , BST, or PZT may be used. For the organic insulating film, general purpose polymer (PMMA, PS), polymer derivatives having phenol-based group, acrylic-based polymer, imide-based polymer, aryl ether-based polymer, amide-based polymer, fluorine-based polymer, p-xylylene-based polymer, vinyl alcohol-based polymer, and a blend thereof may be used. Also, the planarization layer **215** may be made out of a complex laminated body of inorganic insulating films and organic insulating films.

[0035] The pixel unit **200b** is formed on the planarization layer **215**, and may include a pixel electrode **231**, an intermediate layer **232**, and an opposite electrode **233**. The pixel electrode **231** is formed on the planarization layer **215**, and is electrically connected to one of the source and drain electrodes **223** through a contact hole **230** formed in the planarization layer **215**. The pixel electrode **231** may be a reflective electrode and may include a reflective film and a transparent or translucent electrode layer formed on the reflective film, wherein the reflective film is made out of Ag, Mg, Al, Pt, Pd, Au, Ni, Nd, Ir, Cr, or a compound thereof while the transparent or translucent electrode layer may be made out of at least one or more of indium tin oxide (ITO), indium zinc oxide (IZO), zinc oxide (ZnO), indium oxide (In_2O_3), indium gallium oxide (IGO), and aluminum zinc oxide (AZO).

[0036] The opposite electrode **233** that is opposite to the pixel electrode **231** may be a transparent or translucent electrode, and may be made out of a metal thin film having small work function, which includes Li, Ca, LiF/Ca, LiF/Al, Al, Ag, Mg, and a compound thereof. Also, an auxiliary electrode layer or a bus electrode may be further made out of a transparent electrode-forming material, such as ITO, IZO, ZnO, or In_2O_3 , on the metal thin film.

[0037] Accordingly, the opposite electrode **233** may transmit light emitted from an organic light-emitting layer included in the intermediate layer **232**. That is, the light emitted from the organic light-emitting layer may be directly output or reflected by the pixel electrode **231** made out of a reflective electrode to be output towards the opposite electrode **233**.

[0038] However, the organic light-emitting display apparatus **10** according to the present embodiment is not limited to a top-emission type, and may be a bottom-emission type where the light emitted from the organic light-emitting layer is emitted towards the substrate **100**. In this case, the pixel electrode **231** may be made out of a transparent or translucent electrode, and the opposite electrode **233** may be made out of a reflective electrode. Also, the organic light-emitting display apparatus **10** according to the present embodiment may be a dual emission type emitting light in both directions of the top and bottom surfaces thereof.

[0039] A pixel-defining film **216** is made out of an insulating material and is arranged on the pixel electrode **231**. The pixel-defining film **216** exposes a predetermined region of the pixel electrode **231**, and the intermediate layer **232** is dis-

posed on the exposed region, wherein the intermediate layer **232** includes an organic light-emitting layer.

[0040] The organic light-emitting layer may be made out of a low molecular organic material or a polymer organic material. The intermediate layer **232** may selectively further include, besides the organic light-emitting layer, a functional layer, such as a hole transport layer (HTL), a hole injection layer (HIL), an electron transport layer (ETL), and an electron injection layer (EIL).

[0041] Referring now to FIG. 1, the dam unit **120** is formed separately from the display unit **200** on the substrate **100**. That is, the dam unit **120** surrounds a periphery of the display unit **200**.

[0042] The dam unit **120**, as to be described later, improves the adhesion between the substrate and a mask **400** (see FIG. 4) used to pattern the organic film **310** of the encapsulating layer **300** to effectively prevent a monomer of material used to form the organic film **310** from permeating a gap between the substrate **100** and the mask **400** in FIG. 4 during formation of the organic film **310**. By preventing the organic film **310** from being exposed to the outside, the lateral water vapor resistance of the organic light-emitting display apparatus **10** is improved.

[0043] The dam unit **120** is an elastic member made out of any one of silicon, an epoxy, and an acryl. Accordingly, when combined with the mask **400** in FIG. 4, the dam unit **120** can change its shape according to a shape of a groove **410** formed in the mask **400**, as shown in FIG. 4, and may then return to its original shape after the mask **400** in FIG. 4 is removed.

[0044] Since the dam unit **120** exists on a periphery of the display unit **200**, a permeation path of moisture or oxygen permeating the display unit **200** from an external portion of the organic light-emitting display apparatus **10** may be lengthened. Accordingly, the water vapor resistance of the organic light-emitting display apparatus **10** can be further improved. In order to further increase water vapor resistance and although not shown in the drawings, the dam unit **120** may include a plurality of dams separated from each other to allow a permeation path of moisture or oxygen to be further lengthened.

[0045] The encapsulating layer **300** encapsulates the display unit **200** to prevent degradation of the display unit **200**. FIG. 1 exemplifies the encapsulating layer **300** including a single organic film **310** and a single inorganic film **320**, but the present invention is not limited thereto. The organic film **310** and the inorganic film **320** may instead be alternately laminated a plurality of times.

[0046] The organic film **310** is formed to cover the display unit **200**, and may be spaced-apart from the dam unit **120**. The organic film **310** is made out of an organic material having flexibility, such as polyurea, or polyacrylate to relax the internal stress of the inorganic film **320**, or increase the effect of preventing external moisture or oxygen permeation by filling minute cracks and pinholes of the inorganic film **320**. The inorganic film **320** may be made out of an inorganic material having an excellent moisture-proof capability, such as SiN_x , Al_2O_3 , SiO_2 , or TiO_2 , in order to prevent external moisture or oxygen permeation. Accordingly, the inorganic film **320** is formed to cover the organic film **310**. Also, the inorganic film **320** is formed to cover the dam unit **120**.

[0047] Although not shown in the drawings, in the display unit **200**, an inorganic film (not shown) is first formed, and then the organic film **310** and another inorganic film **320** may be sequentially formed. In this case, the dam unit **120** is

formed on the substrate **100** and may be covered by an additional inorganic film (not shown).

[0048] Turning now to FIGS. **3** to **6**, FIGS. **3** to **6** are cross-sectional views schematically illustrating a method of manufacturing the organic light-emitting display apparatus **10** in FIG. **1**, according to an embodiment of the present invention. First, referring to FIG. **3**, the dam unit **120** is formed on the substrate **100**, and then the display unit **200** is formed inside the dam unit **120**.

[0049] The dam unit **120** may be produced by an inkjet printing or a screen printing technique. The inkjet printing is performed by printing ink containing a material of silicon, an epoxy, or an acryl on a corresponding portion to form the dam unit **120**. The screen printing is performed by positioning a mask (not shown) having openings in correspondence to a position at which a dam unit is to be formed on the substrate **100**, and then moving a squeeze rubber (not shown) in one direction and passing a paste containing silicon, an epoxy, or an acryl through the openings to form the dam unit **120**. Although the dam unit **120** may be produced by an inkjet printing or a screen printing technique, the present invention is not limited thereto as the dam unit **120** may instead be produced by a coating method, such as spin coating or depositing, and then performing a photo etching process.

[0050] After the dam unit **120** is formed, the display unit **200** is formed. The display unit **200** is formed inside the dam unit **120** to be separated from the dam unit **120**. The display unit **200** may not only have the configuration exemplified in FIG. **2**, but may also employ any well-known organic light-emitting display. Accordingly, a detailed description of its manufacturing method is omitted.

[0051] Next, the encapsulating layer **300** is formed to encapsulate the display unit **200**. First, as shown in FIG. **4**, the mask **400** is attached to the substrate **100**, and then, as shown in FIG. **5**, the organic film **310** is formed to cover the display unit **200** by using the mask **400**.

[0052] The groove **410** having the dam unit **120** inserted into it is formed in the mask **400**. Here, the depth of the groove **410** may be equal to or smaller than the height of the dam unit **120**, and the width of the groove **410** may be equal to or greater than the width of the dam unit **120**. Here, the width of the groove **410** is measured on the same plane as one surface of the mask **400** abutting on the substrate **100**, namely, a width of a portion into which the dam unit **120** begins to be inserted. As described above, when the width of the groove **410** is equal to or greater than the width of the dam unit **120**, the dam unit **120** may be easily inserted into the groove **410**, even when an error occurs in a mask aligning process.

[0053] In addition, since the dam unit **120** has elasticity, the size and shape of the dam unit **120** can elastically varies according to a shape of the groove **410** when combined with the groove **410**. Accordingly, since the depth of the groove **410** is equal to or smaller than the height of the dam unit **120**, the dam unit **120** ends up abutting both sides of the groove **410**, the result being that the mask **400** adheres to the substrate **100**.

[0054] The groove **410** may have a tapered shape with a lower portion having a width greater than an upper portion, the upper portion corresponding to the opening of the groove **410**. Due to this, the coherence between the dam unit **120** and the groove **410** is improved.

[0055] The organic film **310** is formed when the mask **400** is combined with the substrate **100**. Since it is difficult to directly deposit a polymer, such as polyurea or polyacrylate,

which is a material of the organic film **310**, the organic film **310** may be formed by evaporating a liquefied monomer for deposition onto the substrate **100**, and emitting ultraviolet rays onto the deposited monomer for polymerization.

[0056] At this time, since the evaporated monomer is non-directional, if there is a gap between the mask **400** and the substrate **100**, the evaporated monomer may permeate the gap. However, due to combination of the groove **410** and the dam unit **120** according to the present invention, the mask **400** of FIG. **5** may strongly adhere to the substrate **100**, and permeation of the evaporated monomer into the gap may be minimized. Accordingly, the formation of a general edge tail is prevented, and the organic film **310** may be formed to be separated from and spaced apart from the dam unit **120**.

[0057] Even though there is a gap between the mask **400** and the substrate **100**, and the evaporated monomer permeates the gap, the dam unit **120** may block the evaporated monomer from spreading to the periphery.

[0058] Next, as shown in FIG. **6**, the mask **400** in FIG. **5** is separated from the dam unit **120** of the substrate **100**, and then the inorganic film **320** is formed. The inorganic film **320** may be formed through sputtering, atomic layer deposition, or chemical vapor deposition by using a mask (not shown) for forming the inorganic film **320**.

[0059] The inorganic film **320** is formed to cover the organic film **310** and the dam unit **120**. Since the inorganic film **320** is formed to cover the organic film **310**, the periphery of the organic film **310** is covered by the inorganic film **320** that has excellent moisture-proof properties, and the organic film **310**, which is flexible but vulnerable to moisture, is not exposed to the outside. Therefore the encapsulating layer **300** having a very stable water vapor resistance may be realized.

[0060] In the above description, it is exemplified that the encapsulating layer **300** includes the single organic film **310** and the single inorganic film **320**, however, the present invention is not limited thereto, as the encapsulating layer **300** may instead include a plurality of the organic films **310** and a plurality of inorganic film **320** alternately laminated. Also, the encapsulating layer **300** may instead include a first inorganic film (not shown) being first formed, and an organic film **310** and a second inorganic film **320** being sequentially formed and still be within the scope of the present invention. Even in this case, the dam unit **120** is formed on the substrate **100** and is covered by an additional inorganic film (not shown).

[0061] According to the embodiments of the present invention, lateral moisture-proof characteristics of an organic light-emitting display apparatus can be improved by preventing an organic film from permeating a gap between a mask and a substrate during formation of the organic film.

[0062] While the present invention has been particularly shown and described with reference to exemplary embodiments thereof, it will be understood by those of ordinary skill in the art that various changes in form and details may be made therein without departing from the spirit and scope of the present invention as defined by the following claims.

What is claimed is:

1. An organic light-emitting display apparatus, comprising:
 - a substrate;
 - a display unit arranged on the substrate;
 - a dam unit arranged at a periphery of the display unit and on the substrate; and

- an encapsulating layer to encapsulate the display unit, wherein the encapsulating layer includes an organic film covering the display unit, and an inorganic film covering the organic film and the dam unit, and wherein a hardness of the dam unit is lower than that of the inorganic film.
2. The organic light-emitting display apparatus of claim 1, wherein the organic film is spaced apart from the dam unit.
 3. The organic light-emitting display apparatus of claim 1, wherein the dam unit comprises a material selected from a group consisting of silicon, an epoxy and an acryl.
 4. The organic light-emitting display apparatus of claim 1, wherein the dam unit comprises a plurality of dams spaced apart from each other and parallel to each other.
 5. The organic light-emitting display apparatus of claim 1, wherein the dam unit has elasticity.
 6. The organic light-emitting display apparatus of claim 1, wherein the organic film comprises a material selected from a group consisting of polyurea and polyareylate.
 7. The organic light-emitting display apparatus of claim 1, wherein the inorganic film comprises a material selected from a group consisting of SiN_x , Al_2O_3 , SiO_2 , and TiO_2 .
 8. The organic light-emitting display apparatus of claim 1, further comprising a lower inorganic film covering the display unit and the dam unit, the organic film covering the lower inorganic film.
 9. The organic light-emitting display apparatus of claim 1, the display unit comprises an organic emission layer that is susceptible to moisture and oxygen.
 10. The organic light-emitting display apparatus of claim 4, wherein the plurality of dams are concentric rectangles that increase a length of a lateral path of moisture in reaching the display unit from an outside.
 11. A method of manufacturing an organic light-emitting display apparatus, comprising:
 - forming a dam unit on a substrate;
 - forming a display unit inside the dam unit and on the substrate; and
 - forming an encapsulating layer on the display unit to encapsulate the display unit, wherein the forming of the encapsulating layer includes:
 - combining a mask with the substrate, the mask having a groove into which the dam unit is inserted;
 - forming an organic film to cover the display unit by using the mask;
 - separating the mask; and
 - forming an inorganic film to cover the organic film and the dam unit.
 12. The method of claim 11, wherein a depth of the groove is equal to or smaller than a height of the dam unit, and a width of the groove is equal to or greater than a width of the dam unit.
 13. The method of claim 11, wherein the dam unit comprises a material selected from a group consisting of silicon, an epoxy and an acryl.
 14. The method of claim 11, wherein the dam unit is produced by a technique selected from a group consisting of an inkjet printing technique and a screen printing technique.
 15. The method of claim 12, wherein the groove has a tapered shape.
 16. The method of claim 15, wherein when the dam unit is combined to the groove, a shape of the dam unit changes elastically according to a shape of the groove.
 17. The method of claim 11, wherein the organic film is spaced apart from the dam unit.
 18. The method of claim 11, wherein a hardness of the dam unit is lower than that of the inorganic film.
 19. The method of claim 11, further comprising forming a lower inorganic film to cover the display unit and the dam unit, wherein the organic film is formed to cover a portion of the lower inorganic film, and wherein the combining the mask to the substrate includes inserting the dam unit covered by the lower inorganic film into the groove of the mask.
 20. The method of claim 11, wherein the organic film comprises a material selected from a group consisting of polyurea and polyareylate, the organic film being produced by evaporating a liquefied monomer that is non-directional.

* * * * *

专利名称(译)	有机发光显示装置及其制造方法		
公开(公告)号	US20140306195A1	公开(公告)日	2014-10-16
申请号	US14/036430	申请日	2013-09-25
[标]申请(专利权)人(译)	三星显示有限公司		
申请(专利权)人(译)	三星DISPLAY CO. , LTD.		
当前申请(专利权)人(译)	三星DISPLAY CO. , LTD.		
[标]发明人	OH MIN HO CHO YOON HYEUNG KIM YONG TAK LEE SO YOUNG KIM JONG WOO MOON JI YOUNG		
发明人	OH, MIN-HO CHO, YOON-HYEUNG KIM, YONG-TAK LEE, SO-YOUNG KIM, JONG-WOO MOON, JI-YOUNG		
IPC分类号	H01L27/32 H01L51/56		
CPC分类号	H01L51/56 H01L27/3295 H01L51/0011 H01L51/5246 H01L51/5253 H01L2251/56 H05B33/04 H05B33/10 H01L27/3246		
优先权	1020130040547 2013-04-12 KR		
其他公开文献	US9735223		
外部链接	Espacenet USPTO		

摘要(译)

一种有机发光显示装置及其制造方法。有机发光显示装置包括基板，布置在基板上的显示单元，布置在显示单元的周边和基板上的阻挡单元以及用于密封显示单元的封装层，其中封装层包括：覆盖显示单元的有机薄膜和覆盖有机薄膜和阻挡单元的无机薄膜，其中阻挡单元的硬度低于无机薄膜的硬度。据此，改善了有机发光显示装置的横向防潮特性。

